

# USER MANUAL

Model: KD-WH150M

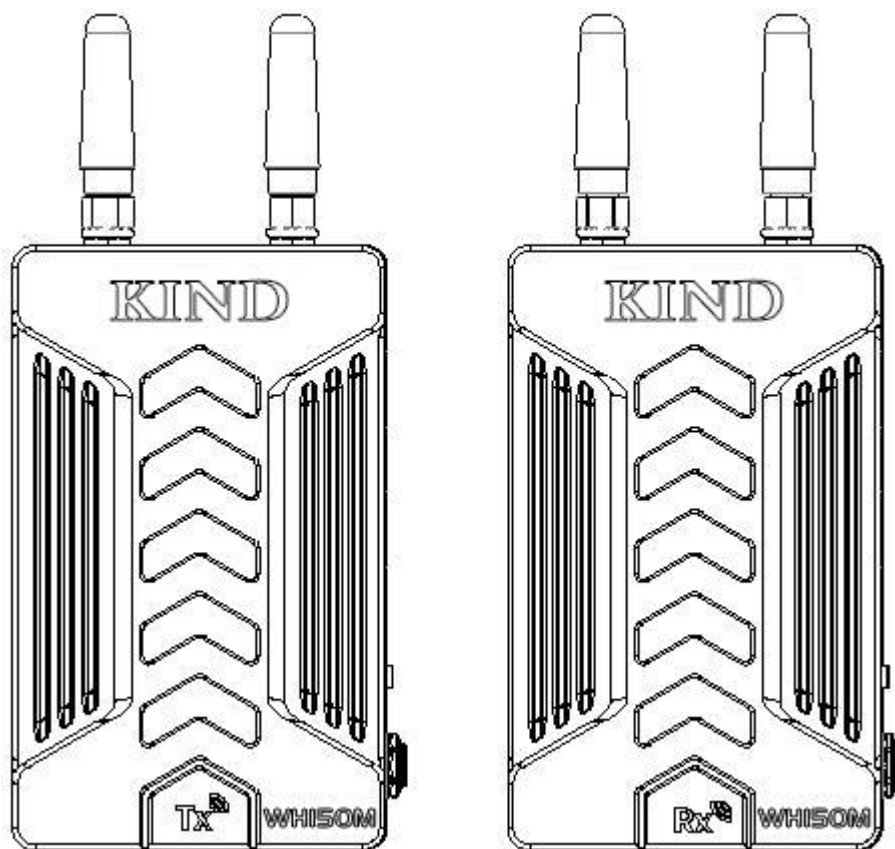

Thank you for choosing KIND product, please read this user manual throughout before using.

## Preface

1. All internal technologies of this product are protected, including device, software and trademark. Reproduction in whole or in part without written permission is prohibited.
2. ALL brands and trademarks are protected and other relative trademarks in this user manual are the property of their respective owners.
3. Due to constant effort of product development, KIND reserves the right to make changes and improvements to the product described in this manual without prior notice.
4. Not cover the following:
  - (1) Physical damage to the products
  - (2) Any damage or breakdown caused by use, maintenance, or storage not according to the user manual's introductions.
  - (3) The attenuation of signal quality resulting from being used in any special environments.
  - (4) Any damage caused by not powering the product by package supplied power adaptor.
  - (5) Any damage or breakdown not caused by the product's design, workmanship, manufacturing, quality, or unauthorized repairs or parts replacement or other operations.
5. For any suggestions and requirements on this product, please contact us, please contact us through phone, fax, Email, etc.

## Safety Precautions

Please follow the safety precautions before using . The following conditions are not covered by warranty.

1. Unauthorized repairs or other Unauthorized operations.
2. Inappropriate placement including but not limited to lighting, fire, exposure to rain, water or gas.
3. Using the wrong power supply



### Warning

- Do not get any liquid inside the products
- Do not block the ventilation openings or put substances inside, in order to avoid short circuit, fire or electric shock.
- Do not place the product in the rain or moisture to avoid electric shock or fire.



### Danger

- Switch the power off before connecting other devices.
- Power socket: Make sure the power socket under the voltage range of the product to avoid short circuit, electric shock and fire.
- Power cable: Make sure the power cable is not pressed or tightened by any items or weights.
- Power Load: Do not exceed the load on the wall outlet, extension cable or other porous receptacle to avoid fire or electric shock.
- Lightning: Disconnect the power cable if it is lightning or not using in long period of time.

## Working environment

- Please don't lay the product on any unstable place to avoid fallen damage.
- Please don't use the product in a place overheating, undercooling or with lots of moisture, or nearby strong magnetic devices.
- Please don't lay the product on metal shelf, in order to ensure the effective wireless transmission.

## Packing list

1. Transmitter
2. Receiver
3. Antenna\*4
4. D-tap to lockable pole cable (0.6m)
5. Power adaptor
6. User manual

## 1. Product Introduction

This model includes transmitter and receiver, adopts the latest encrypted transmission technology, Supports HDMI wirelessly transmitted in 150 meters scale(Line-of-sight), 1 channel HDMI digital video transmission, auto pairing. It is equipped with DC power connector, compact size, portable, and the receiving signal is very stable.

## 2. Features

### ◆ HDMI Wireless transmission

Support up to 1080P50/60Hz HDMI wireless transmission.。

### ◆ 150 meters transmission distance

In open outdoor area, the effective transmission distance is approx. 150 meters (line of sight).

### ◆ Wireless frequency

The system adopts 5180~5220MHz and 5760~5820MHz Wireless frequency band

Frequency Band and Frequency point			
CH00	5180MHz	CH04	5780MHz
CH01	5200MHz	CH05	5800MHz
CH02	5220MHz	CH06	5820MHz
CH03	5760MHz	/	/

The system adopts 5182.5~5282.5MHz and 5762.5~5822.5MHz Wireless frequency band

Frequency Band and Frequency point			
CH00	5182.5MHz	CH04	5782.5MHz
CH01	5202.5MHz	CH05	5802.5MHz
CH02	5222.5MHz	CH06	5822.5MHz
CH03	5762.5MHz	/	/

### ◆ Pairing mode

Support auto pairing connection and manual switching of frequency points.

### ◆ Encryption

Support AES 128-bit encryption to protect the transmission.

### ◆ All-Metal Shell

Both the transmitter and receiver adopt metal shell which is durable and solid.

### ◆ All hardware design

The wireless system is hardware and plug-and-play designed, without installing software, easy to set up.

## Remark:

1. The transmission distance may be different, and depend on surroundings, radio wave conditions, buildings, etc., the 150 meters transmission distance may be not guaranteed.
2. The wireless transmission might be interrupted if there' re other devices of 5Ghz wireless bandwidth used in the same location.
3. Signal reception may be affected by the position, height and angle of devices. If reception video is not stable, please physically adjust placement for the optimized signal.
4. Set the antennas straight up and set receiver higher to enhance the transmission efficiency.

## 3. Appearance Instruction

### Transmitter

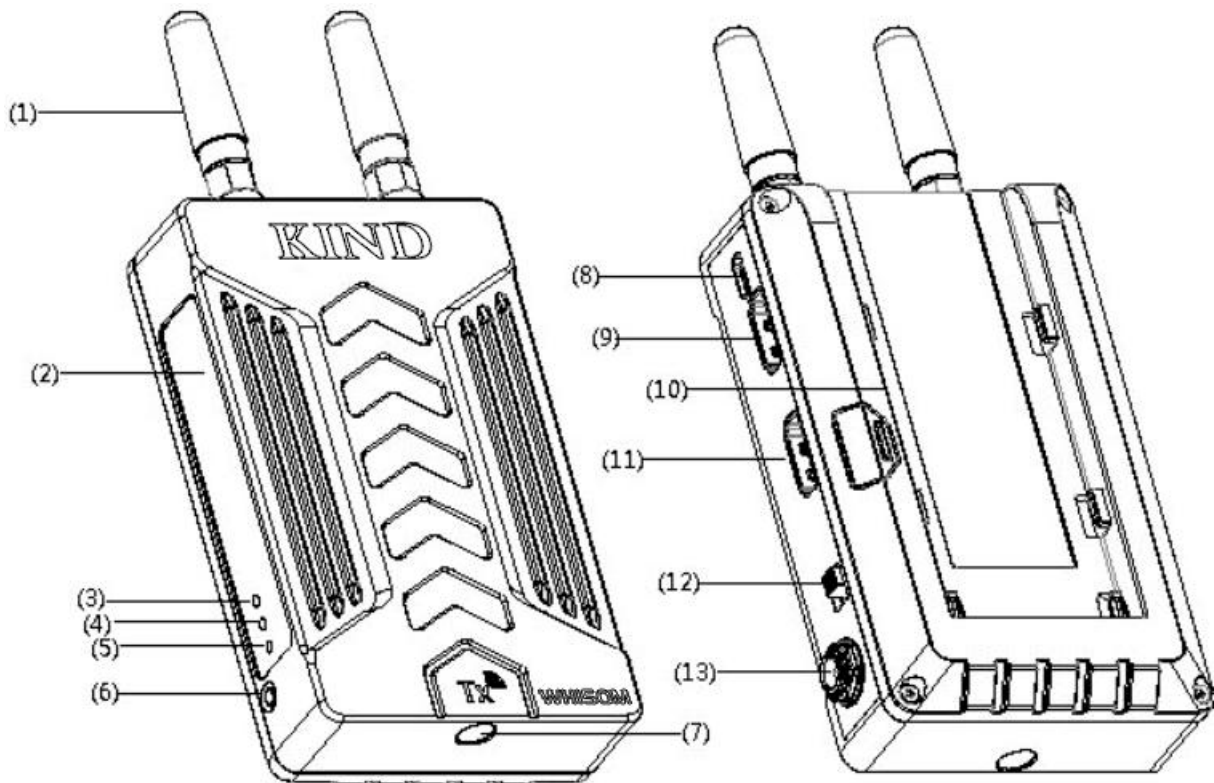

- (1) Antenna
- (2) **Product label**
- (3) **Link:** Wireless status indicator
- (4) **Video:** Video signal indicator
- (5) **Power:** Power status indicator
- (6)**Pair:** 0.96-inch OLED
- (7)**Installation thread:** 1/4"-20 thread. Use the package supplied articulating arm trestle to install the device to the camera.
- (8) **USB:** Micro USB, software upgrade interface
- (9) **HDMI in:** HDMI input (standard HDMI-A type connector).
- (10)**Battery plate:** "F" plates can be used. compatible with SONY "L" series NP-F770/970/.
- (11) **HDMI LOOP:** HDMI loop out (standard HDMI-A type connector).

(12) **ON/ OFF:** Power switch

(13) **DC in:** Support DC 7~17V input,5.5mm(outer diameter)/2.1mm(inner diameter)  
 Outside: negative, Inside: positive

Device	LED indicator	Status	Description
Transmitter	Power	Constant on	Power connected and switched on
		Off	Power disconnected and switched off
	Video	Constant on	There is recognizable video signal input
		Flash	There is no recognizable video signal input
	Link	Constant on	The wireless network connection is normal
		Flash	The wireless network connection is abnormal

The description of LED status indicator

## Receiver

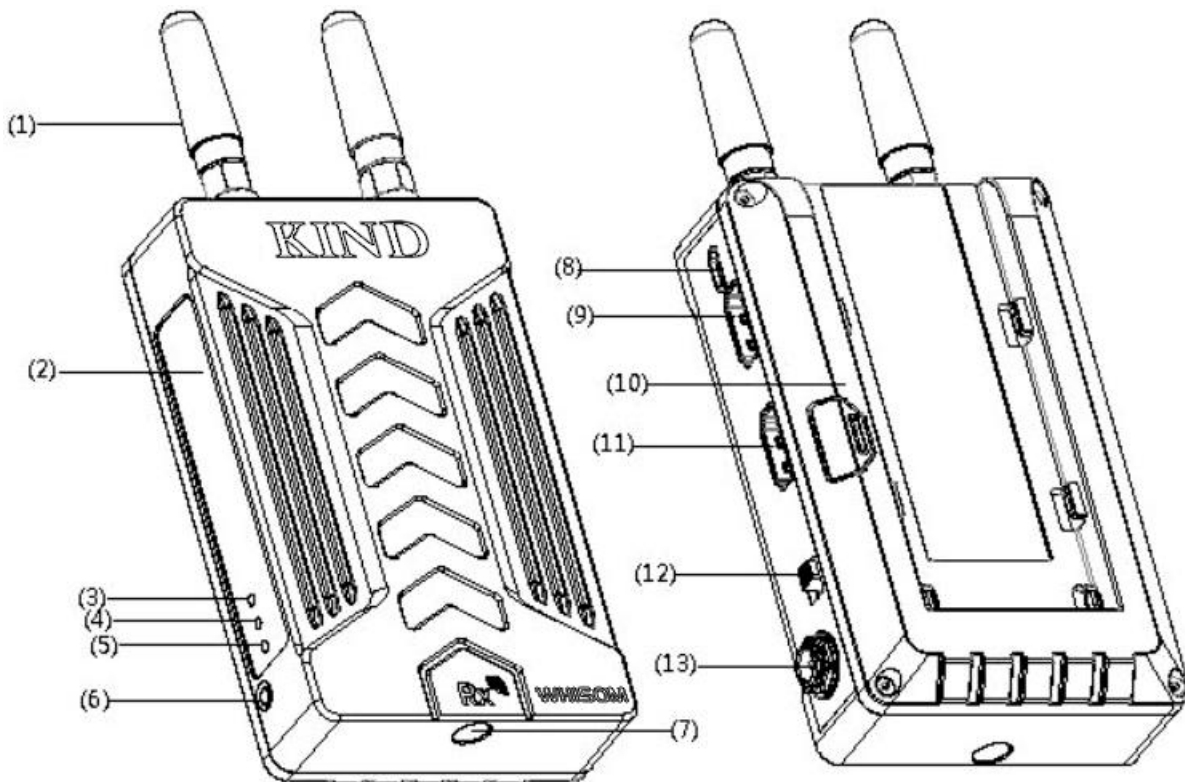

- (1) Antenna
- (2) **Product label**
- (3) **Link:** Wireless status indicator

- (4) **Video:** Video signal indicator
- (5) **Power:** Power status indicator。
- (6) **Pair:** Pair button。
- (7) **Installation thread:** 1/4"-20 thread, Use the package supplied articulating arm trestle to install the device to the camera
- (8) **USB:** Micro USB, software upgrade interface
- (9) **HDMI OUT:** HDMI output (standard HDMI-A type connector).
- (10) **Battery plate:** "F" plates can be used. compatible with SONY "L" series NP-F770/970/.
- (11) **HDMI OUT:** HDMI output (standard HDMI-A type connector).
- (12) **ON /OFF:** power switch
- (13) **DC in:** Support DC 7~17V input,5.5mm(outer diameter)/2.1mm(inner diameter)  
Outside: negative, Inside: positive

The description of LED status indicator

Device	LED indicator	Status	Description
Receiver	Power	Constant on	Power connected and switched on
		Off	Power disconnected and switched off
	Video	Constant on	There is recognizable video signal input
		Flash	There is no recognizable video signal input
	Link	Constant on	The wireless network connection is normal
		Flash	The wireless network connection is abnormal

## 4. Setup connection

- (1) Connect the HDMI in interface of transmitter to the HDMI out of the camera or video output device.
- (2) Connect the HDMI out interface of receiver to the HDMI in of the monitor or switch station.
- (3) Connect the power supply of transmitter and receiver, the "power" indicator will light up, "Link" and "Video" indicator light up when the transmitter and receiver have identifiable signal inputs and connections, "Link" and "Video" indicator will flash if transmitter and receiver have no identifiable signal input.

Tips: 1. put the power switch to "ON" when connect the power supply of transmitter and receiver.

2. The transmitter only supports the HDMI video input interface, and the system automatically detects the input video interface.

## 5. Pairing

- (1) Connect the HDMI in interface of transmitter to the HDMI out of the camera or video output device.
- (2) Connect the HDMI out interface of receiver to the HDMI in of the monitor or switch station.
- (3) Connect the power supply of transmitter and receiver, the "power" indicator will light up "Video" and "Link" indicator will flash.
- (4) Long pressing the "pair" button in both transmitter and receiver, The "Link" indicator of transmitter and receiver flash and pair, "Link" indicator lights up, the automatic pairing is successful and enters the encrypted transmission state.
- (5) Press the "Pair" button twice apartly to upgrade the firmware, the "Video" indicator quickly flashing during upgrade process, "Video" "Link" indicator light up with red, the firmware upgrade successfully. The "Video" "Link" indicator flash when upgrade is failure

Tips: 1. When pairing, the transmitter and receiver need to be paired Simultaneously.

2. During normal use, ensure that the wireless device used has been paired and successfully paired.

3. The paired transmitter and receiver will be automatically connected after booting up. It is no need to pair again.

4. Please keep the transmitter and receiver in distance of 1-2m to avoid pairing failure.

## 6. The way to get the best effective of Wireless Transmission

- (1) Set the antenna on both transmitter and receiver vertically straight up. No request to spread.  
(Fig.1)

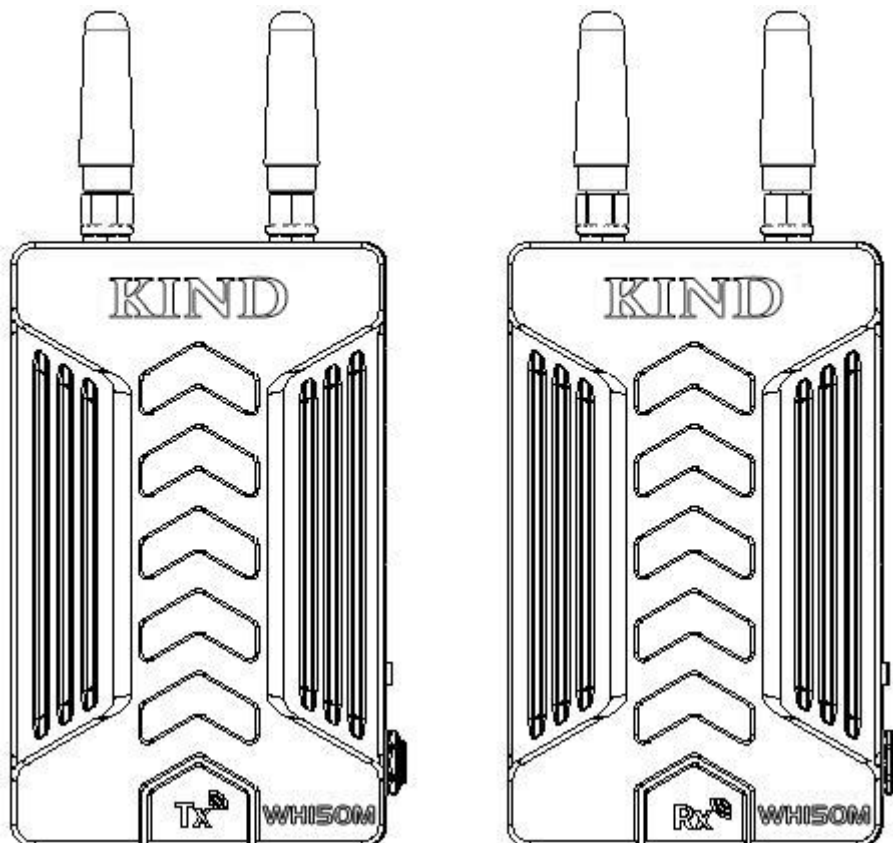
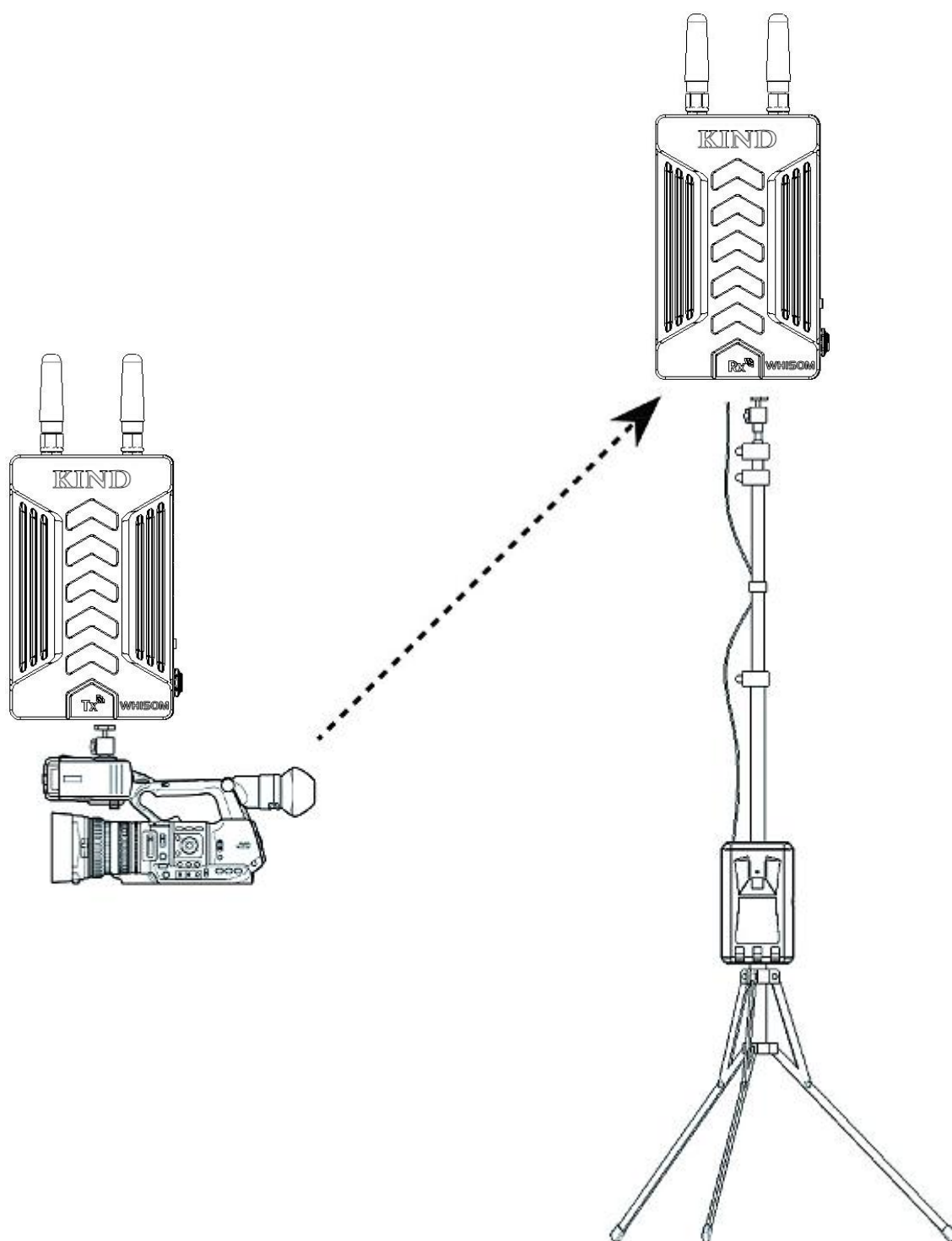

Fig.1



# KIND<sup>®</sup>

- (2) Set the receiver as high as possible to avoid interference.



(3) Avoid walls, trees and water to reduce signal attenuation.

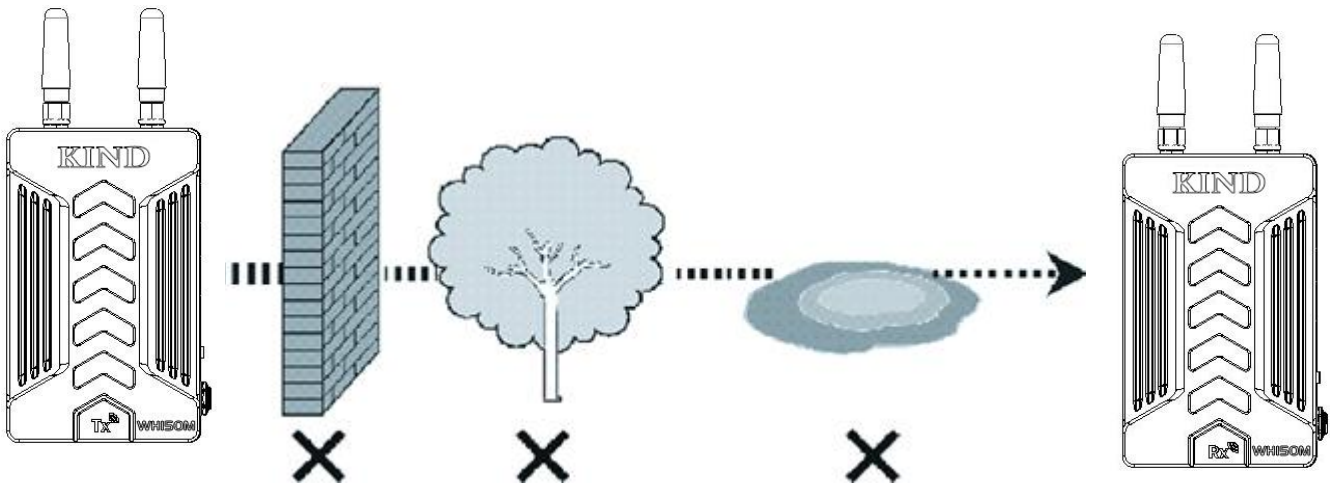

## 7. Trouble shooting

If the receiver failed to output video correctly, the possible causes are as below; please find the solution from following chart:

The receiving video	Possible causes	Soultion
No display	The transmitter or the receiver is not powered on	Check power connection and switch on the transmitter and receiver
	The antennas are not installed properly and screwed tightly	Install the antennas properly and screw tightly of both transmitter and receiver
	Bad connection of video cable	Check video cable connection of both transmitter and receiver
	Video format is not supported	Change the output video format of the camera
Poor Video quality	Bad connection with video cable	Reconnect reliably
	The wireless transmission is disturbed by environment	Wait for 1 minute or reboot the transmitter and receiver
	The transmission distance is out of effective range	Put the transmitter closer to the receiver

## 8. Specification

Model	Transmitter	Receiver
Input	HDMI×1	/
Output	HDMI×1	HDMI×2
Video format	1080I (60 / 59.94 / 50) / 720P (60 / 59.94 / 50) / 1080P (60 / 59.94 / 50 / 30 / 29.97 / 25 / 24 / 23.98)	
Wireless frequency	FULL:5180-5220MHz and 5760-5820MHz	
Modulation mode	OFDM Support 16QAM、64QAM、QPSK、BPSK modulation mode	
Transmission distance	150m (Line of sight)	
Power consumption	≤7.5W	≤7W
Input voltage	DC / Battery: 7~17V	DC / Battery: 7~17V
Working environment	Temperature: 0°C~+40°C	
Dimension	114.18×69.55×28 (mm)	114.18×69.55×28 (mm)
Net weight (Without antenna)	190.7g	193.3g
Net weight (With antenna)	198.6g	201g

### FCC Statement

Any Changes or modifications not expressly approved by the party responsible for compliance could void the user's authority to operate the equipment.

This device complies with part 15 of the FCC Rules. Operation is subject to the following two conditions:

- (1) This device may not cause harmful interference, and
- (2) This device must accept any interference received, including interference that may cause undesired operation.

### FCC Radiation Exposure Statement:

This equipment complies with FCC radiation exposure limits set forth for an uncontrolled environment .

This equipment should be installed and operated with minimum distance 20cm between the radiator& your body.

Note : This equipment has been tested and found to comply with the limits for a Class B digital device, pursuant to part 15 of the FCC Rules. These limits are designed to provide reasonable protection against harmful interference in a residential installation. This equipment generates,uses and can radiate radio frequency energy and, if not installed and used in accordance with the instructions, may cause harmful interference to radio communications. However, there is no guarantee that interference will not occur in a particular installation. If this equipment does cause harmful interference to radio or television reception, which can be determined by turning the equipment off

and on, the user is encouraged to try to correct the interference by one or more of the following measures:

- Reorient or relocate the receiving antenna.
- Increase the separation between the equipment and receiver.
- Connect the equipment into an outlet on a circuit different from that to which the receiver is connected.
- Consult the dealer or an experienced radio/TV technician for help.

---

## **Beijing kind Network Technology Co. LTD**

Address: 16C, Unit 1, Building C, Yingdu PLAZA, No. 48, Zhichun Road, Haidian District, Beijing,China.

Official website:[WWW.KINDLIVECAST.COM](http://WWW.KINDLIVECAST.COM)

Zip Code: 100086

Phone: +86 010-58732646